

REQ'D.	EXIST.	PROP.	
		LOT 1	LOT 2
LOT AREA	8000 *	31978	23949
FRONTAGE	80'	99'	59'
WIDTH	80'	90'	90'
SETBACKS			
FRONT	20'	12.1'	48'
SIDE (RT)	15'	49.7'	15.4'
SIDE (LT)	15'	1.6'	17.7'
REAR	20'	296'	114'
STORIES	3	2	3
HEIGHT	35'	35'<	35'<
LOT COV.	40%	2.5%	9.3%
OPEN SPACE	10%	83%	

* 12,000- DUPLEX

LEGEND

EXISTING CONTOUR	---126---
EXISTING SPOT GRADE	124X2
SEWER MANHOLE	OSMH
PROPOSED CONTOUR	128
DRAIN LINE	D
SEWER LINE	S
SEWER SERVICE	SS
WATER SERVICE	WS
WATER GATE	WG
CATCH BASIN	CB
GAS LINE	G

NOTES:

- 1) CONTRACTOR TO VERIFY LOCATION, SIZE, AND INVERT OF ALL EXISTING UTILITIES.
- 2) CONTRACTOR SHALL BE RESPONSIBLE TO FIND AND TIE INTO EXISTING UTILITIES.
- 3) CONTRACTOR TO NOTIFY DIG-SAFE PRIOR TO ANY CONSTRUCTION.
- 4) WATER SERVICE TO BE 1" TYPE "K" COPPER.
- 5) SEWER SERVICE TO BE 6" PVC 2.00% MIN. SLOPE FROM HOUSE TO PUMP & 1" FORCE MAIN TO MANHOLE.
- 6) WATER & SEWER LATERALS SHALL BE 10' APART (min)
- 7) BENCHMARK: MAG NAIL EL. = 136.43

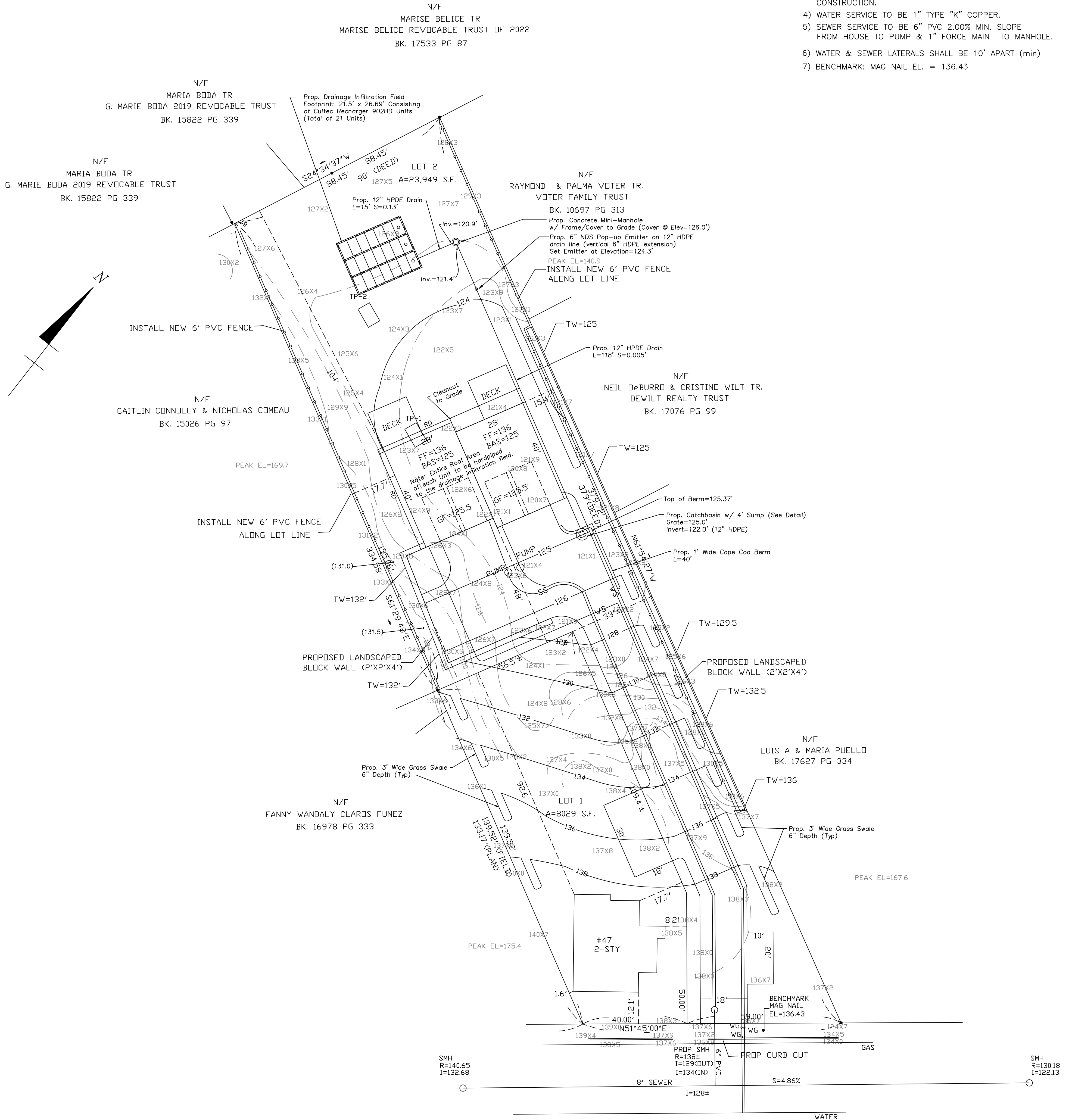

LOWELL STREET

SHEET 1 OF 2



PAUL J. FINOCCHIO P.L.S. No.36115 DATE



JOHN D. SULLIVAN III, P.E. No. 41586 DATE

PROPOSED SITE PLAN
OF
47 LOWELL STREET
IN
METHUEN, MA

PREPARED BY: P.J.F. AND ASSOCIATES
4 HIGHLAND AVENUE
WAKEFIELD, MA 01880
(781) 883-5473

REV. 1/22/25
REV. 12/27/24
REV. 8/2/24

0' 10' 20' 30' 40'
SCALE: 1" = 20'

DATE: DECEMBER 31, 2023 FILE No. 7967P5

FIELD	PLOT	DESIGN	DRAFT	CALC.	CHECK

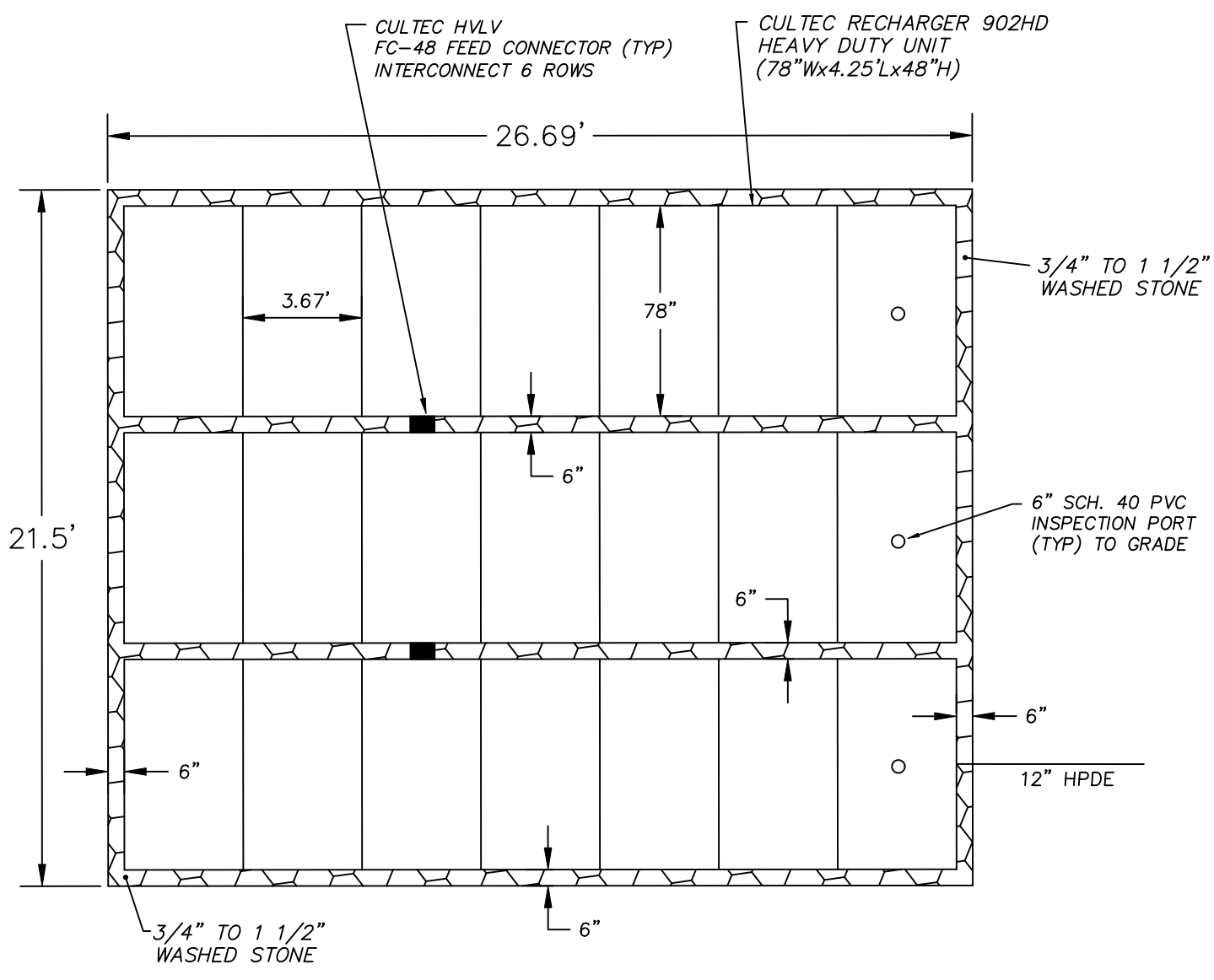

3 ROWS OF 7 CULTEC 902HD RECHARGERS (21 UNITS TOTAL)
SUBSURFACE INFILTRATION SYSTEM
 (NOT TO SCALE)

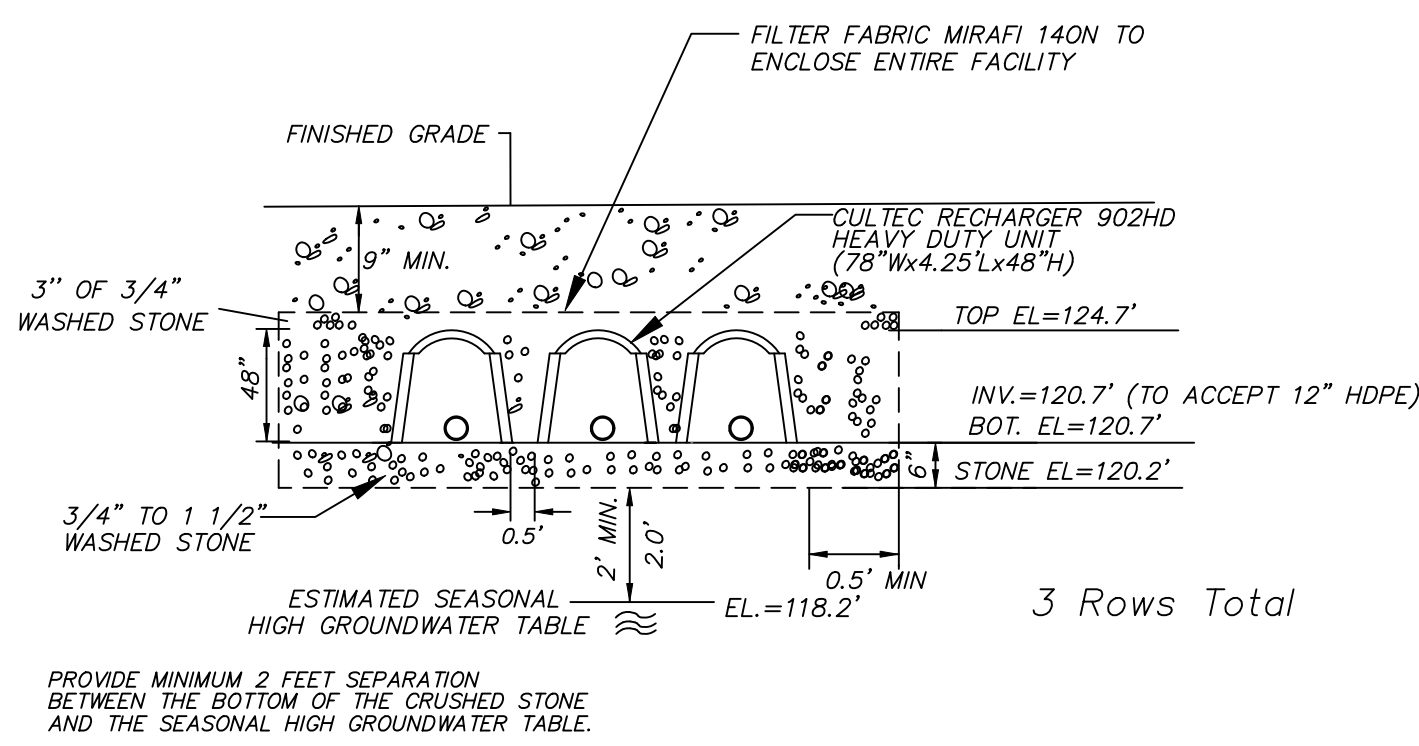

SUBSURFACE INFILTRATION SYSTEM - CROSS SECTION
 (NOT TO SCALE)

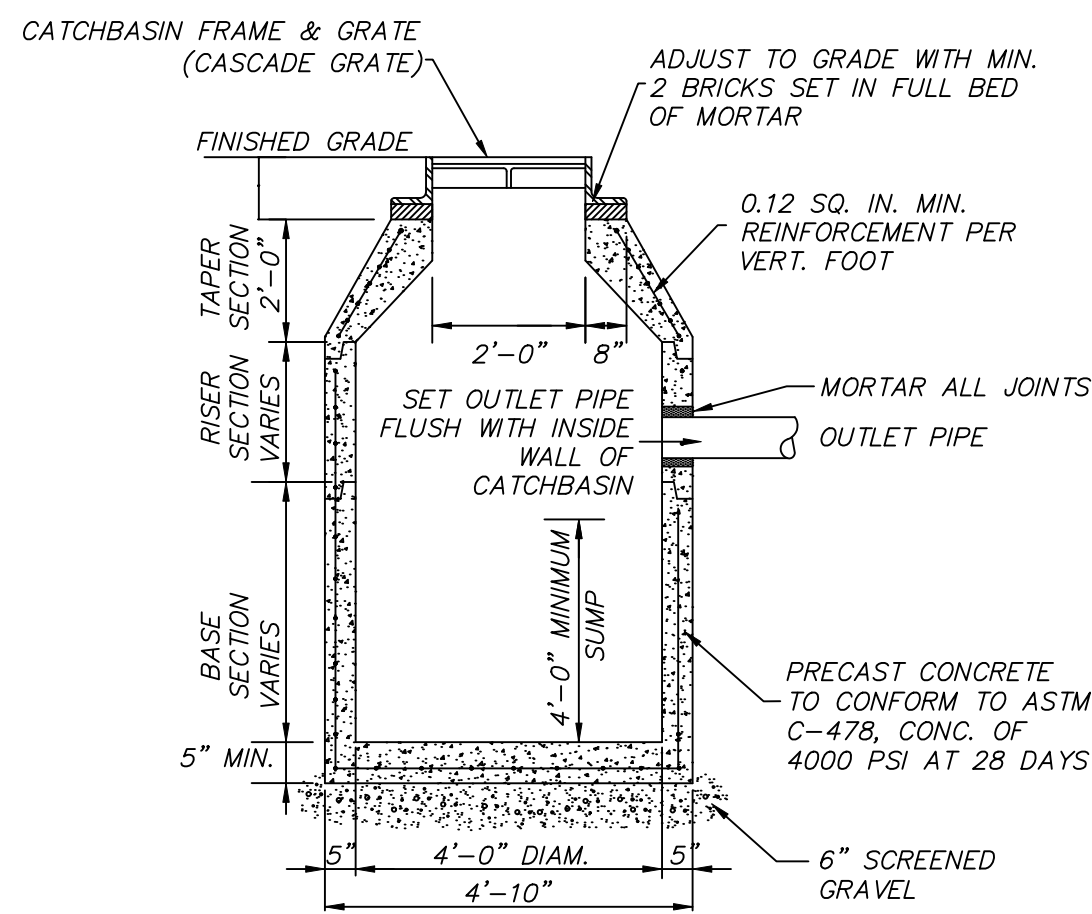

TYPICAL CONCRETE CATCH BASIN
 (NOT TO SCALE)

SOILS INFORMATION:

SOIL TESTHOLES PERFORMED BY JOHN D. SULLIVAN III, PE, CSE ON 10/24/2024 AND WITNESSED BY JOSEPH GIARRUSSO OF THE CITY OF METHUEN (CONSERVATION OFFICER)

TEST PIT: TP-1
 ELEV.=123.8'±
 G.W. ELEV.=NOT OBSERVED

0"-8" HORIZON A: SANDY LOAM 10 YR 3/3
 8"-24" HORIZON Bw: LOAMY SAND 10 YR 6/8
 24"-96" HORIZON C: M-C SAND (Stratified) 2.5 Y 6/4

E.S.H.G.W. < ELEV 115.8'
 RAWLS RATE USED: 8.27 IN/HR

TEST PIT: TP-2
 ELEV.=125.2'±
 G.W. ELEV.=NOT OBSERVED

0"-42" FILL
 42"-52" HORIZON Bw: LOAMY SAND 10 YR 6/8
 52"-84" HORIZON C: M-C SAND (Stratified) 2.5 Y 6/4

E.S.H.G.W. < ELEV 118.2'
 RAWLS RATE USED: 8.27 IN/HR

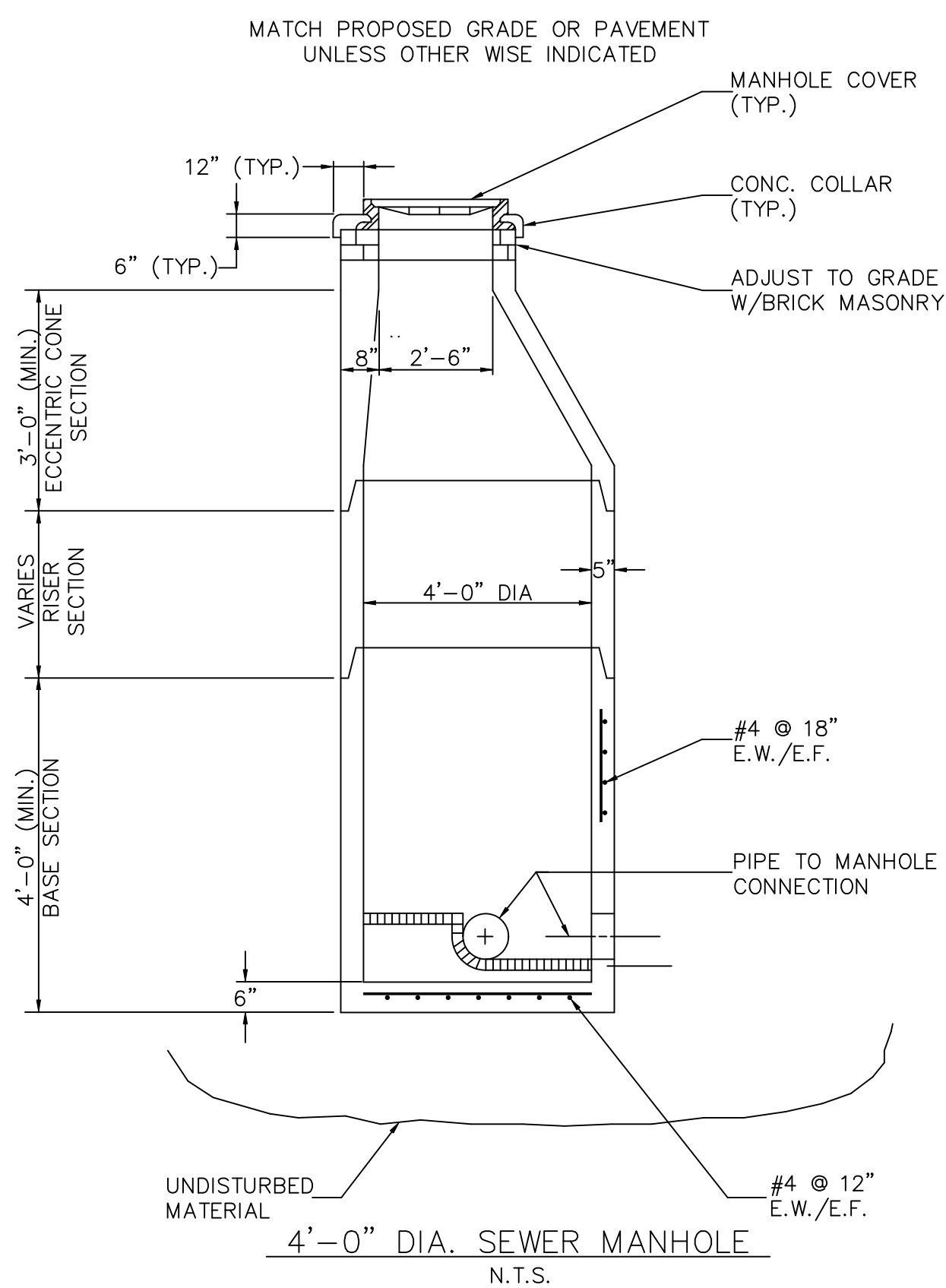

4'-0" DIA. SEWER MANHOLE
 N.T.S.

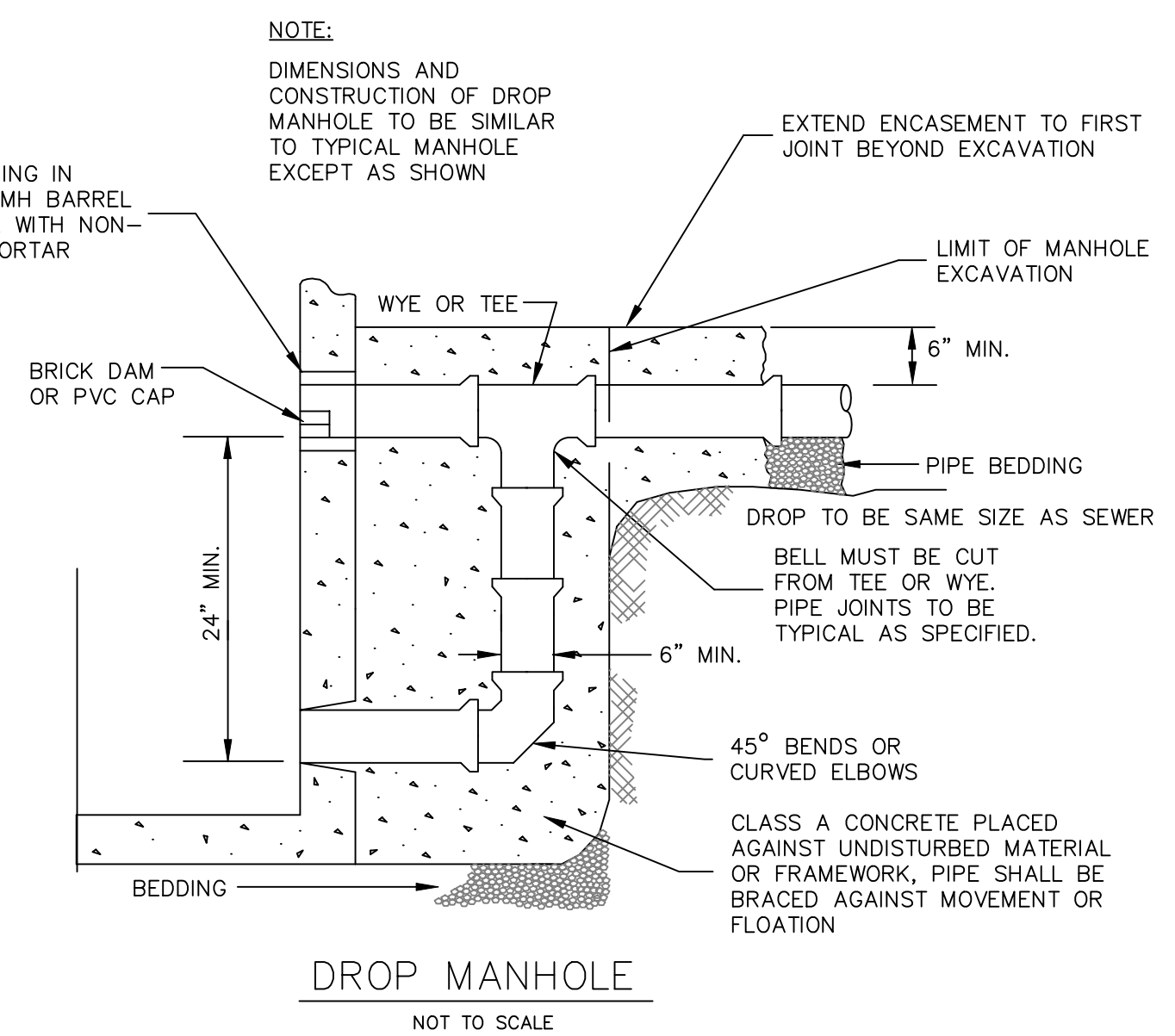

DROP MANHOLE
 NOT TO SCALE



PAUL J. FINOCCHIO P.L.S. No.36115 DATE



JOHN D. SULLIVAN III, P.E. No. 41586 DATE

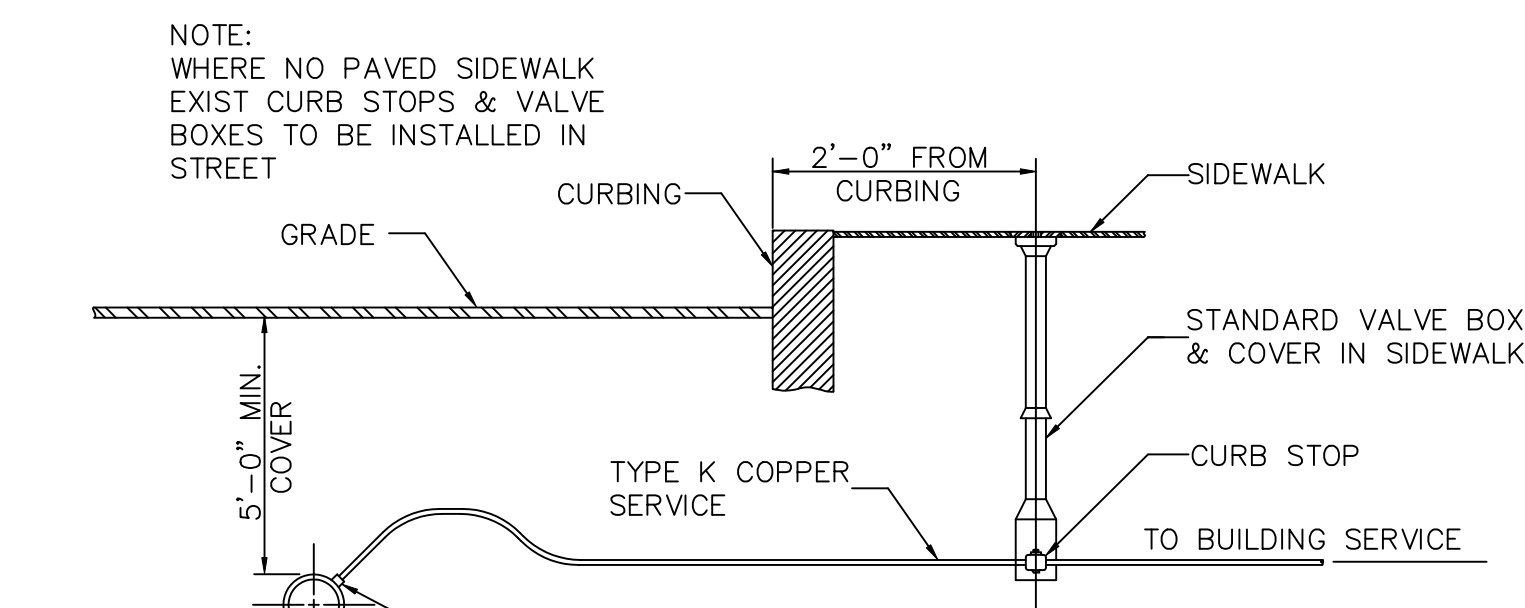

COPPER SERVICE CONNECTION
 NOT TO SCALE

SHEET 2 OF 2

DETAIL SHEET
 OF
 47 LOWELL STREET
 IN
 METHUEN, MA

PREPARED BY: P.J.F. AND ASSOCIATES
 4 HIGHLAND AVENUE
 WAKEFIELD, MA 01880
 (781) 883-5473

REV. 1/22/25
 REV. 12/27/24
 REV. 8/2/24

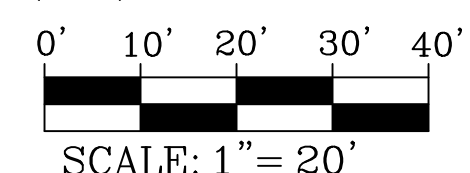

DATE: DECEMBER 31, 2023

FILE No. 7967P5A

FIELD	PLOT	DESIGN	DRAFT	CALC.	CHECK

JOHN D. SULLIVAN III, P.E. No. 41586 DATE